



***AFTER INSTALLING KIT IN YOUR CAR
SEND US PHOTOS – WE WILL ADD THEM TO OUR WEBSITE
THANKS***

office@airride-system.pl

[#airridesystem](https://www.instagram.com/airridesystem)

[FB: @airRIDESystem](https://www.facebook.com/airRIDESystem)

[IG: @mapettuning airridesystem](https://www.instagram.com/mapettuning_airridesystem)

UNIVERSAL **INSTALLATION GUIDE**

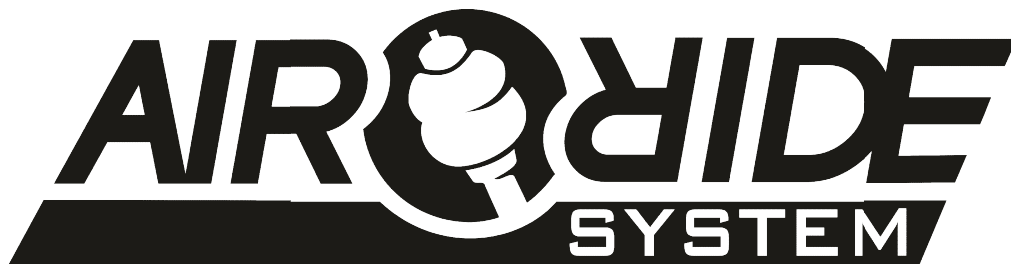

ATTENTION Installation manual and all information within are the property of airRIDE-System.pl

Copying or distributing them is a copyright infringement.

TABLE OF CONTENTS

1. INTRODUCTORY INFORMATION
2. INSTALLATION OF BAGBRACKETES on a threaded shock absorber
3. WIRED REMOTE CONTROL PINS SCHEMATIC
4. VALVE DESCRIPTION
5. AIRRIDE DIAGRAM
6. COMPRESSOR INSTALLATION AND USE
7. AIRRIDE SCHEME

1 INTRODUCTORY INFORMATION

The airRIDE-System.pl suspensions are not approved or certified to be used on public roads. They are built specifically for exhibition cars. Anyone who uses them on regular streets, does it on their own responsibility. We have been building air-suspensions since 2011 and have a long history of working with sports suspensions (www.mapet-tuning.com).

2 INSTALLATION OF BAGS

CAUTION! This step should be skipped, if you have purchased a set including shock absorbers!

To install the Bag Brackets, screw them on the thread and seal them. You can seal the Airspring Brackets using e.g. adhesive for threaded joints, teflon, silicone, glass adhesive and other sealing compounds. Sealing of threads with larger thread size is more difficult, therefore it is recommended to use silicone-density adhesives for coarse threads with the pitch over 2mm.

An important element is the placement of the bottom bracket on the shock absorber. To utilize the travel of the absorber optimally, the fitting should be threaded low enough so that when the top bracket is pressed with hands, it touches the shock absorber casing inside the air bag (fig. 2) (fig. 3 shows what it should look like without the air bag). However, it is important to remember about the dimensions of rims and tires. When positioning the fittings, remember to first check whether they fit behind the wheel and, if necessary, correct their placement. If you want to adjust how low the car sits (when it sits too low and, for example, the wheel scrapes the wheel arch), we recommend placing a polyurethane bumper inside or above the top bracket, to reduce the down-travel of the suspension.

CAUTION! You have to fit the bag bracket to your car top bearing perfectly! Sometimes it is necessary to cut something or put some washers or slim spacers to work properly!

In ARS2 bag suggested distance from the top of shock to the bottom of bag bracket is 8,5cm and in ARS3 bag this distance should be about 9,5cm.

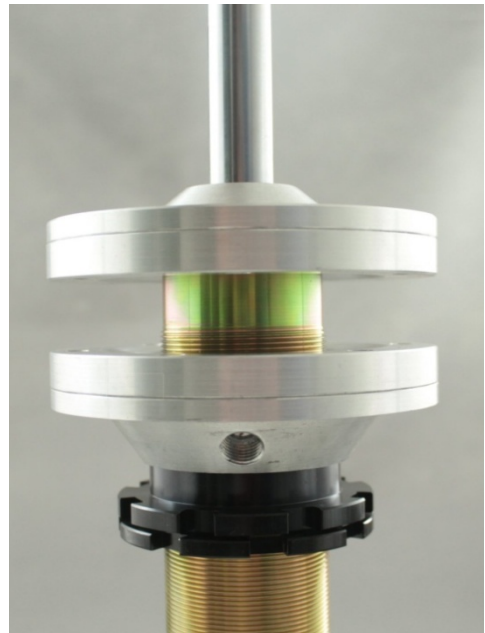

3 WIRED REMOTE CONTROL PINS

List by plug pins:

1. right side rear lowering
2. left side rear lifting
3. right side front lowering
4. left side rear lowering
5. right side rear lifting
6. right side front lifting
7. left side front lifting
8. left side front lowering
9. power control with plus 12V

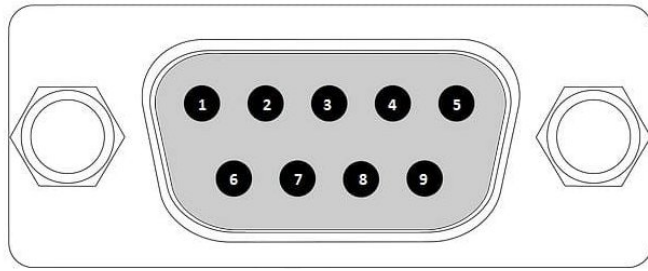

IMPORTANT!

If you also want to connect a WIRELESS remote control, it is recommended to use directional led that will not allow the current to flow in the direction of the wireless remote control panel.

4 VALVE DESCRIPTION

Below, we present an example 5/3-way valve used in our sets.

There are two options:

- each wheel separately - 4 valves are needed
- each axle separately - 2 valves are needed

Example Technical specification:

12V controlled model

Type 5/3

Connections 1/4"

Use - air

Max. working pressure 11bars

Working temperature from -5 to 80 degrees Celsius

Compact valve with airbags emptying and filling function

Simple assembly!

2 usable inputs

Controlled with two 12V

With pneumatic systems, it is obligatory to use dryers (watertraps) - air pre-conditioning systems - which will allow you to keep the pneumatic system clean and avoid tank corrosion, or damaging the components of the suspension and the control elements of the system. This is a necessary prerequisite of the warranty! It is recommended to install "control" dewatering valves in the tank.



CAUTION! Only connect the control wires of the 2 parallel pins to the coil, the 3rd pin should stay disconnected!

5 CIRCUIT DIAGRAM

IMPORTANT!

It is best to consider the fuses when connecting the +12V power!

We present an example installation diagram. CAUTION! Standard manometers are NOT illuminated.

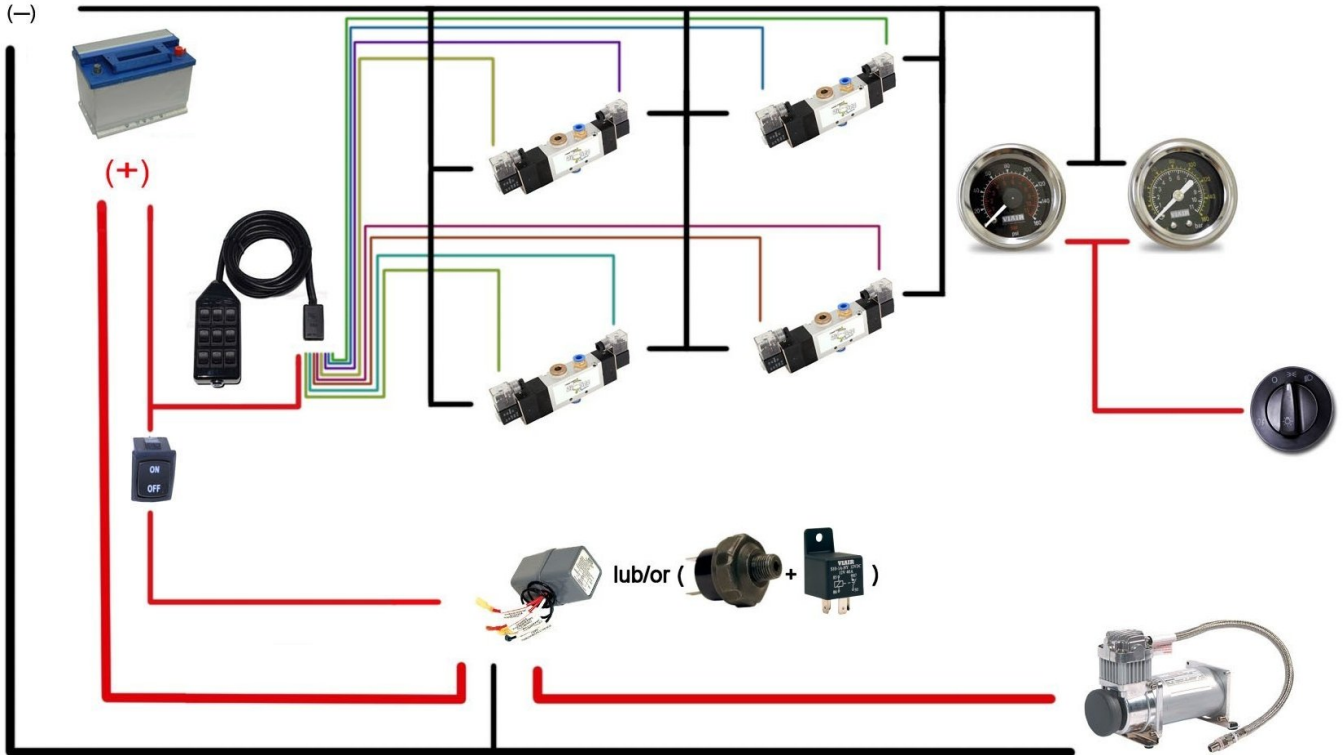

CAUTION! To connect the compressor, use at least 6 mm² diameter wire and a fuse 30-40A
 To connect the remote control and pressure switch, use a 0.25-0.5 mm square diameter wire and a fuse around 7.5A

Relay, pressure sensor and compressor installation diagram:

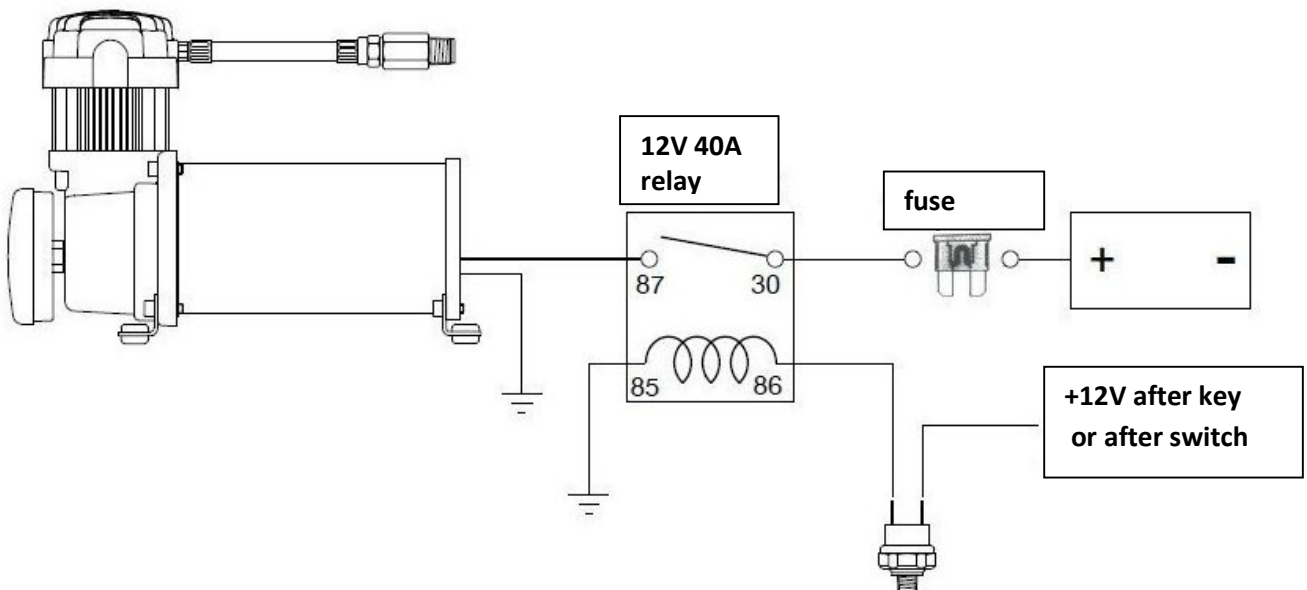

6 COMPRESSOR INSTALLATION AND USE

Initial REMARKS:

1. Do not try to repair or modify the compressors.
2. Do not use the product where it can be flooded with water or other liquids.
3. The compressor should only be used in 12V installations.
4. The products should never be left unsupervised when in use.
5. Never allow children to use the compressor.
6. The compressor heats up considerably during and directly after use. Do not touch any of its elements with bare hands during and directly after use.
7. Never use the product close to fire or explosive materials.
8. Never use the device in places where oxygen is supplied.
9. Do not pump anything other than atmospheric air with the device.
10. Do not direct the air nozzle at another person.
11. The compressor is equipped with an automatic temperature off switch. Always disconnect the device from the power source when the switch is activated.
12. Use only in well ventilated spaces.

Please, read and follow the installation manual to avoid bodily harm, as well as compressor or vehicle damage.

Installation instructions:

Choosing the right spot for the air compressor will help provide long and seamless service life of the compressor.

1. Select flat surface in a secure spot where the compressor can be installed.
2. To maximize the performance of the air compressor, it is best to place it close to the battery.
3. Select an installation place as far from heat sources as possible.
4. Never install the compressor in places where it is likely to come into contact with water.
5. Make sure that the air filter inlet is located in a dry place.
6. Seal the connection well. Large amount of Teflon tape is not recommended.

INSTALLATION:

1. Disconnect the ground cable from the vehicle battery.
2. Temporarily place the air compressor in the spot where it will be installed.
3. Connect the ground wire to the battery (-) or appropriate grounding point.
4. Installation of the air compressor is done using 4 screws in designated places.
5. Install the provided air filter.
6. The compressor is equipped with steel-braided hoses, with 380C / 444C -1/4" or 485C - 3/8" NPT threading at the ends. Do not remove the hose from the compressor.
7. The compressor hose has an integrated backflow preventer. It should not be removed!
8. Connect + cable to the compressor, from the relay to the pressure switch.
9. Insert an appropriate power fuse onto the + cable from the battery. Place the fuse as close to the power source as possible.
10. Before connecting to the power source, double check all connections.
11. Connect and test the system by starting the compressor for a short time and check the pressure increase in the air tank.
12. Once the air pressure reaches the value set by the pressure switch, the compressor should shut down. Check all of the air connections, e.g. with water and soap solution.

NOTICE:

1. Always use the compressor at or below its maximum pressure level.
2. If, at any given moment during its operation, the compressor shuts down automatically, do not try to restart it. You

can continue to safely use the compressor after leaving it for around 30 minutes to cool off.

5. To avoid discharging the car battery, it is recommended to keep the engine running while using the compressor. The performance of the compressor is then increased.

CAUTION! Make sure the compressor does not heat up drastically. Frequent cooling of the compressor is recommended. If it reaches the temperature of 100 degrees Celsius, it can overheat and shut down!

MAINTENANCE AND REPAIRS

1. Periodically check all electric connections. Clean and tighten if necessary.
2. Periodically check all fixing screws. Tighten if necessary.
3. Periodically change the air filter. The frequency of changes depends on how frequently the device is used and the working environment.
4. Regularly clean the motor cylinder to remove dust and dirt.
5. The air compressor is equipped with motor lubrication system. Never lubricate the compressor.

7 AIRRIDE SCHEME

